



DPS5000 RS485

Digital pressure sensing platform

The DPS5000 RS485 from Baker Hughes, part of the UNIK5000 family, offers integrated digital compensation and signal processing providing performance levels unmatched by traditional analogue sensors. Communication is via RS485 protocol, providing readings of pressure and temperature. Using the fully featured command set, the sensor can be configured for optimum functionality in specific applications.

High quality

With 50 years of pressure measurement experience, our field-proven Druck technology is at the heart of the new platform, resulting in a range of high quality, high stability pressure sensors. The core of this sensor is built around Druck's class-leading proprietary piezo-resistive silicon pressure measurement die, manufactured in Druck's own class 100 clean-room located in the heart of the UK. The DPS5000 RS485 features a fully welded compact design which is robust enough to withstand deployment in the most demanding test applications.

Expertise

We have the people and the knowledge to support your needs for accurate and reliable product performance; our team of experts can help you make the right sensor selection, guiding you and providing the help and tools you need. It is important that you ensure that the sensor materials and performance selected are suitable for your application.

Features

- Ranges from 200 mbar to 700 bar
- Total accuracy to $\pm 0.1\%$ FS
- Stainless steel construction
- Wide temperature range $-40\text{ }^{\circ}\text{C}$ to $125\text{ }^{\circ}\text{C}$
- Fast update rate 10 ms
- Customer set filter setting
- Baud rate up to 230 k bit/s
- Excellent long-term stability

DPS5000 RS485 specifications

Operating pressure ranges

Gauge ranges

Any range from 200 mbar to 103.5 bar (3 to 1500 psi)

Ranges up to 70 bar are enabled in negative gauge to the range or a maximum of -1 bar (-15 psi)

Absolute ranges

Any range from 700 mbar to 700 bar (10 to 10000 psi)

All ranges are zero based

Wet Dry differential

Any range from 200 mbar to 35 bar (3 to 500 psi)

All units are bidirectional

Wet Wet differential

Any range from 700 mbar to 35 bar (10 to 500 psi)

All units are bidirectional

Over pressure

At least 2 × Pressure range with negligible calibration change

For differential versions, the negative side must not exceed its positive side by more than

2 × Pressure range up to a maximum of 15 bar

Containment pressure

4 × Pressure range for gauge ranges
(200 bar (3000 psi) maximum)

200 bar (3000 psi) for absolute ranges below 100 bar
(1500 psi)

1200 bar (17000 psi) for absolute ranges above 100 bar
(1500 psi)

For differential versions, the negative side must not exceed its positive side by more than

2 × Pressure range up to a maximum of 15 bar

Supply

Voltage: 5 Vdc to 32 Vdc

Current: < 10 mA

Output/communications

RS485 Half Duplex

ASCII based DUSTI (Druck Universal Serial Transmission Interface)

Baud rate selectable between 9600 and 230400

See manual for configuration details

Default setting

Function	Value
Baud Rate	9600
Address	01
Pin	000
User Message	<none>

Power on time

500 ms to acquisition from power on

Insulation resistance

> 100 MΩ at 500 Vdc performance

Performance

Pressure performance

Total error band precision (TEB) over the calibrated temperature range including zero and span setting, plus the effects of non-linearity, hysteresis, repeatability, and thermal error.

Pressure range	TEB (% FS)					
	Improved (A2)			Premium (A3)		
	TA	TB	TC	TA	TB	TC
200 mbar g to 103.5 bar g	0.2	0.2	0.4	0.1	0.1	0.2
700 mbar a to 700 bar a	0.2	0.2	0.4	0.1	0.1	0.2
±200 mbar to ±35 bar wet-dry	0.2	0.2	0.4	0.1	0.1	0.2
±700 mbar to ±35 bar wet-dry	0.4	0.4	0.8	0.2	0.2	0.4

1. Increasing pro-rata below lowest range.

2. Values double for barometric range.

Temperature performance

Accuracy over the calibrated temperature range ±3 °C (6 °F) with 0.1 °C (0.2 °F) Resolution

Long term stability

±0.05 % FS/year typical

±0.1 % FS maximum at reference conditions

Increases pro-rata below 700 mbar (10 psi)

Line pressure effects (differential sensors only)

Zero shift: <±0.03% span/bar

Span shift: <±0.03% span/bar

Effects increase pro-rata for ranges below 700 mbar

Physical specifications

See wiring details table

Operating temperature range

-55 °C to 125 °C (-67 °F to 257 °F)

Pressure media

Fluids compatible with stainless steel 316L and Hastelloy C276

Statement in accordance with the European pressure equipment directive

Not suitable for media that has an oxygen concentration >21% or other strong oxidizing agents. This product contains materials or fluids that may degrade or combust in the presence of strong oxidizing agents.

Enclosure materials

Stainless steel 316L (body)

Pressure connectors

- See ordering information

Other connectors may be available. Contact Druck to discuss your requirement.

Wiring details

Electrical connector	Environmental protection	Wire colour or pin number	Function
Option 'G' M12x1 5-PIN	IP67	1	+ VE Supply
		2	RS485 B
		3	Ground
		4	RS485 A
		5	RT
Option 'G' BAYONET (MIL-C-26482)	IP67	A	+ VE Supply
		B	RS485 B
		C	RS485 A
		D	Ground
		E	RT
		F	-

RT= Terminating Resistor 120R. Short to RS485 A to activate

General certifications

RoHS 2002/95/EC

CRN Certified OF 13650.513467890YTN for pressure ranges up to and including 100 bar

CE conformity

Pressure Equipment Directive 97/23/EC: Sound Engineering Practice

EMC directive 2004/108/EC

BS EN 61326-1:2013

BS EN 61000-6-1: 2007

BS EN 61000-6-3: 2007 + A1:2011

Ordering information

1) Select part number

Main product Variant

DPS Digital Output Transducer

Product Diameter and Material

50 25mm Stainless Steel

Electrical connection

6 MIL-C-26482 Bayonet
G M12 x 1.4-Pin

Electronics option

A RS485 DUSTI

Compensated temperature range

TA -10 to +50 °C
TB -40 to +85 °C
TC -40 to +125 °C

Accuracy

A2 Improved
A3 Premium

Calibration

CC Full thermal

Hazardous area certification

H0 None

Pressure connector

PA G1/4 Female (**Note 1**)
PB G1/4 Male Flat
PE 1/4 NPT Female (**Note 1**)
PF 1/4 NPT Male
PN G1/2 Male
PJ M14 x 1.5 60° Int Cone
PR 1/2 NPT Male
PV 7/16-20 UNJF Female
PZ M10 x 1.0 80° Int Cone

DPS 50 G A - TB - A3 - CC - H0 - PA

Note 1: Choose this pressure connector for range over 103.5 bar (1500 psi).

2) Specify maximum working pressure unit and reference. Available units are:

Symbol	Description	Symbol	Description	Symbol	Description
bar	bar	mmH ₂ O	millimeters water	inHg	inches mercury
mbar	millibar	cmH ₂ O	centimeters water	Kgf/cm ²	Kilograms force/centimeters square
psi	pounds/square inch	mH ₂ O	meters water	atm	atmosphere
Pa	Pascal	in H ₂ O	inches water	Torr	torr
hPa	hecto Pascal	ft H ₂ O	feet water		
kPa	Kilo Pascal	mmHg	millimeters mercury		

3) Specify baud rate (baud rate-9600)

Options

230400

115200

57600

38400

19200

9600 (default if left blank)

Typical order examples

DPS 50GA – TB – A3 – CC – H0 – PZ 700 mbar gauge

DPS 50GA – TC – A2 – CC – H0 – PA 300 mbar wet dry differential

Mechanical drawings

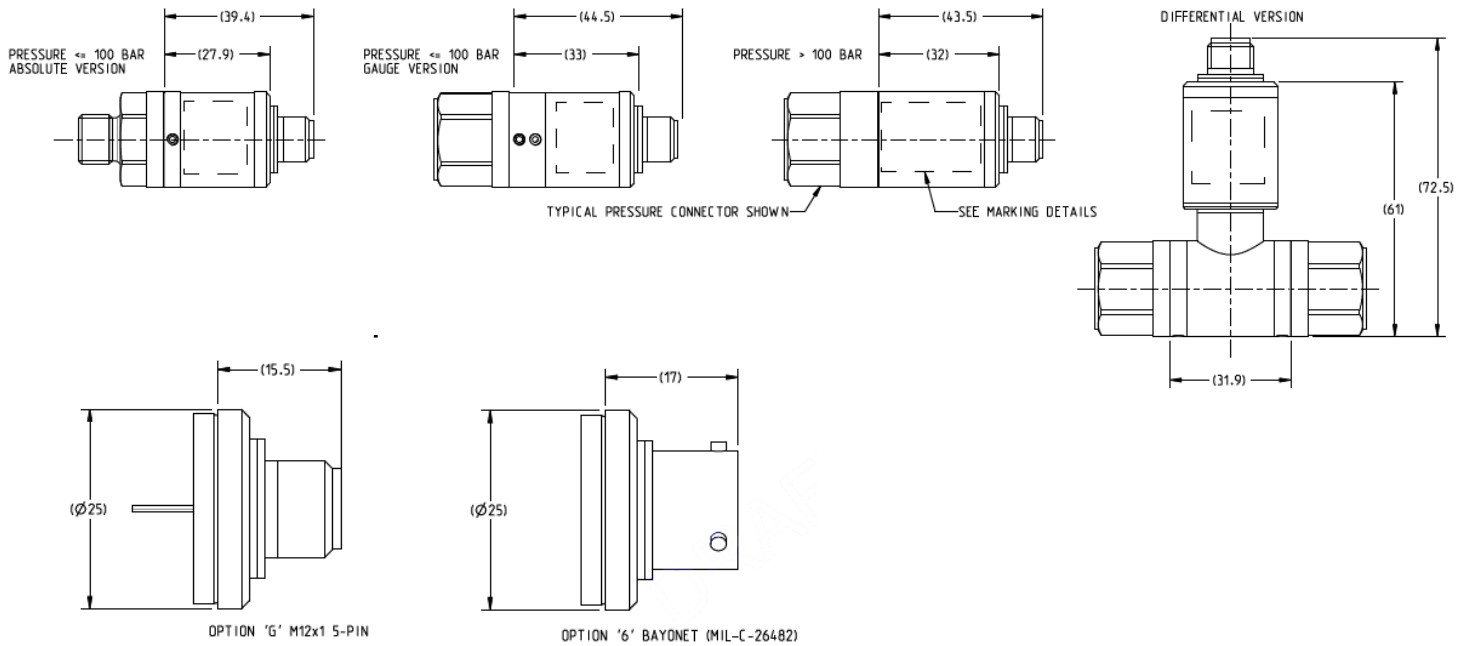

Note: All dimensions in millimeters.

Druck offers a portfolio of high accuracy, high performance test and calibration equipment in safe or hazardous area (IS) variants that are ideal for the calibration and adjustment of Druck's pressure sensors.

Delivering world class
pressure measurement
and calibration technology



2026 Copyright by Druck Limited. All rights reserved.

920-722B

BHCS39549A (03/2026)

 **Druck**

druck.com