

Explosion proof LED spotlight CLN-Ex

Waterproof and compact



Features

- ATEX certified
- Suitable for use in gaseous and dusty environments
Zones 2 and 22
- 24 Volt DC / 4.2 Watt
- 820 lux at 1 metre distance
- Bright daylight
- Tempered glass
- Swivel, or swivel and tilt
- Operating temperature -40 °C to +50 °C



II 3 G Ex ec IIC T4 Gc
II 3 D Ex tc IIIC T135°C Dc



Description

The CLN series is specifically designed for industrial environments where oil, oil mist, cutting fluids and / or waste materials are present (IP66G and IP67G classification).

The ability to swivel and tilt allows users to direct the light exactly where it is needed. The aluminium enclosure and tempered glass protect the unit from any flying debris. The colour temperature of 6500K (daylight white) makes objects easy to see. The operating temperature from -40 °C enables installation in environments with sub-zero temperatures, such as in cold stores.

The CLN LED spotlight is explosion proof and certified in accordance with European Directive 2014/34/EU (ATEX 114) and is CE marked.



Explosion proof LED spotlight CLN-Ex

Waterproof and compact



Technical specification

Explosion safety:	II 3 G Ex ec IIC T4 Gc, II 3 D Ex tc IIIC T135°C Dc
European Directives:	2014/34/EU (ATEX 114) and 2014/30/EU (EMC)
Applied standards:	EN 55011:2006, EN 61000-6-2:2005, EN 60079-0:2018, EN 60079-7:2015 / A1:2018, EN 60079-31:2014
Light output:	820 lx at 1 metre / 200 lx at 2 metres
Enclosure:	Aluminium
Weight model T:	390 g
Weight model PT:	460 g

• T Type

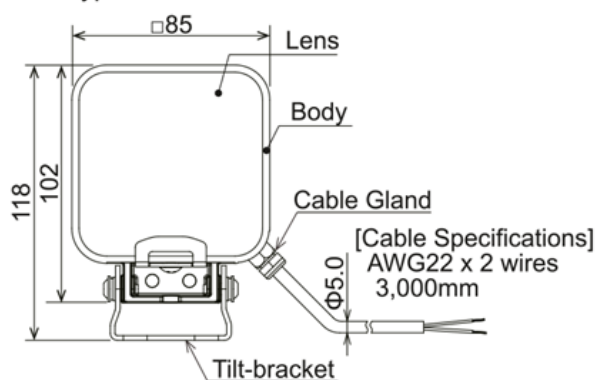

• PT Type

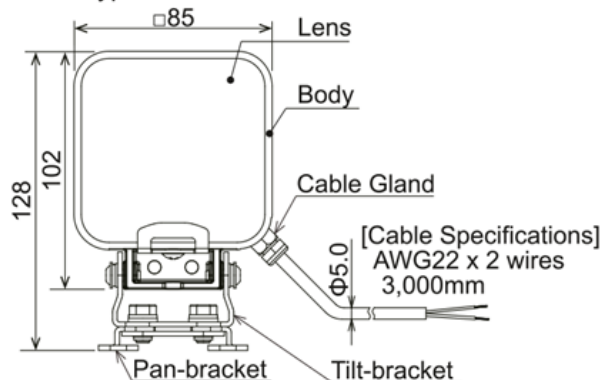

3-2. Angle Adjustment

• T Type

Up and Down Movement

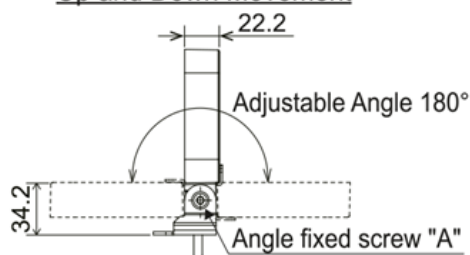

• PT Type

Up and Down Movement

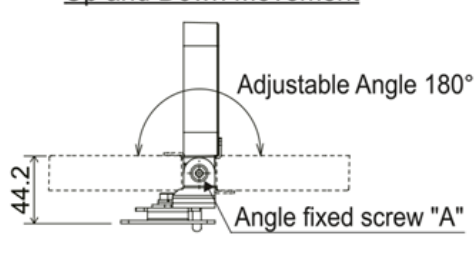

Left and Right Movement

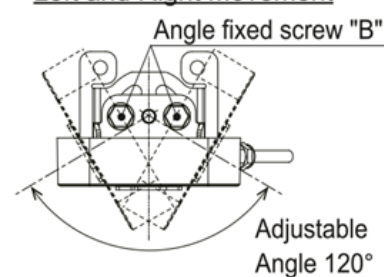

Order code

Type number	Other information
CLN-24A-CD-T-EX	Swivel
CLN-24A-CD-PT-EX	Swivel and tilt